

F|S

FABRICS-STORE.COM

*Our linen is nothing short of addicting*

# CHURCHILL DOG LOUNGE



## DOG DAYS IN LINEN

*Our dogs aren't just our friends- they're family!  
Treat your pet to their own natural linen lounge.  
A dog loved indeed.*

Pattern & instructions for 24", 36", and 42" sizes.

866.620.2008 [ASK@FABRICS-STORE.COM](mailto:ASK@FABRICS-STORE.COM) [FABRICS-STORE.COM](http://FABRICS-STORE.COM)

---

# CHURCHILL PATTERN

---

*Churchill is a cozy round dog bed with a removable linen cover. Linen is the perfect fabric- soft & comfortable for your pet, and durable enough to last through years of wash and wear.*

*Simple instructions for the intermediate level sewist.*

PICTURED: THE CHURCHILL LOUNGE USING OUR 4C22 7.1oz IN NATURAL.



# PATTERN DETAILS

## CHURCHILL BED

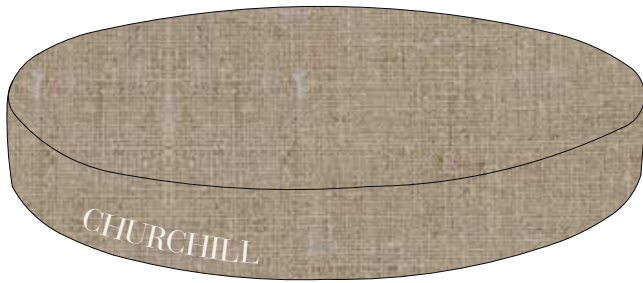

- Removable cover with zipper
- Tailored sides for 3" thick insert
- Diameter sizes 24", 36", 42"
- Optional embroidered monogram

## FABRICS & SUPPLIES

### Fabrics:

[] Main fabric: Washed medium to heavy weight linen. We sampled the Churchill lounge in our 4C22, a heavier weight of 7.1 ounces this 100% linen is referred to as Rustic due to its more textured look and feel.

[] 3" to 3.5" thick round foam cushion 24"/36"/42". You may alternatively use loose stuffing. Durable zipper: for size Small- 37", Medium- 56", Large- 65"

## SIZE & YARDAGE GUIDE

| Estimated Yardage of Unwashed Linen                |               |             |               |
|--|---------------|-------------|---------------|
| 55/56" Width Linen - Shrinkage Has Been Calculated |               |             |               |
|  | SMALL 24" DIA | MED 36" DIA | LARGE 42" DIA |
| Yardage needed                                     | 1.25 YARDS    | 2.5 YARDS   | 2.75 YARDS    |

---

## SEWING & PREPARATION TIPS:

Sewing with quality linen from Fabrics-Store is very enjoyable! Linen is a stable fabric that does not easily shift or slip, which is a very helpful characteristic for sewing a neat and even seam with little effort. You do not need to “push” or “pull” the fabric while sewing... just simply guide it.

*Pre-washing:* You will want to prewash and dry your linen fabric in the same manner you would your finished garment. This will soften your fabric, and eliminate further shrinkage in your final garment.

Secure the raw edges with a zig-zag stitch or serger before washing to avoid fraying. You may also sew the two raw edges together to form a continuous piece to avoid twisting in the wash. Remove fabric from dryer while it is still slightly moist. Press any deep creases or wrinkles using your iron's steam setting with high heat, using a protective press cloth if needed to avoid scorching.

*Fine Seaming:* To ensure that your seaming will last as long as your linen garment, we encourage “single-needle” tailoring and French seaming. Once you think of French seams as simply sewing the seam twice to encase the raw edges, you will see that it does not take that much more time than the second step of using a serger. Setting the stitch length on your sewing machine to 2mm (about 12-14 stitches per inch) makes for a very durable seam, and is also an attractive indication of fine tailoring.

*Alternate Seaming:* If you instead prefer to stitch your seams regularly and serge the raw edges, simply sew the seams with the full 5/8” allowance. You can then serge the raw edges, allowing the machine to trim 1/8” off the edges. This will result in seam allowances finishing at 1/2”.

*Pressing:* For best results, it is highly recommended that you press your seams as you finish sewing each of them. Pressing with a steam iron (and press cloth if needed) will help “set” the stitches into the fabric. You will find it is much easier to press your seams “as you go” instead of trying to press them all after the garment is finished.

*Sewing Glossary:* If certain sewing terms and techniques are new to you, please refer to the sewing glossary at the end of this document.

## PATTERN & CUTTING GUIDE:

Cutting layouts are for pre-washed and preshrunk fabric. For each size, create the indicated circle size. This includes seam allowance. Draft the rectangular band to the dimensions indicated. This includes seam allowance. Snip a notch in 4 equal sections of the circles as indicated in the diagram. Snip a notch in the center of the top and lower edge of each of the bands.

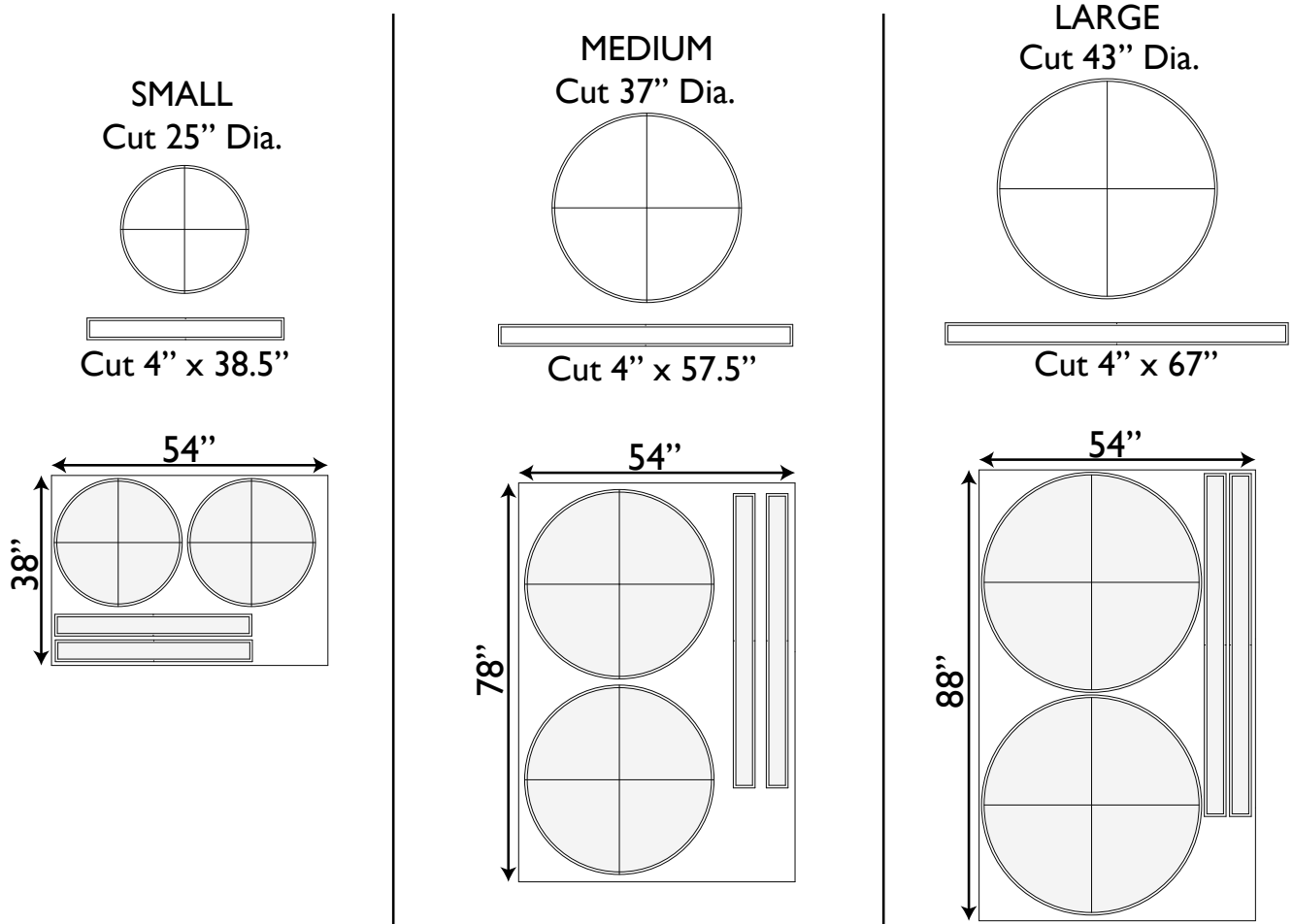

## SEWING INSTRUCTIONS

1. On each of the bands, snip a center notch along the top and bottom length. Optional: Embroider name.
2. Join the two bands together with 1/2" seam allowance.
3. Sew the band all the way around the top circle, aligning notches
4. Sew the lower band to the lower circle only half the distance (front only).
5. Insert your zipper into the lower unseamed edge.

---

## Glossary:

**Basting Stitch:** A temporary hand or machine loose or long stitch to hold a seam in place before sewing the final permanent stitching.

**Bias grain:** In woven fabrics, this is the diagonal direction at 45 degrees to the grain and crossgrain. There are two bias directions in the cloth, perpendicular to each other.

**Buttonhole:** A slit in the fabric to fasten a button. The raw edges of the slit are finished with a machine or hand sewn zig-zag stitch.

**Ease stitch:** A row of stitching sewn just to the inside of a single layer of seam allowance. While stitching, coax the weave of the fabric with your finger or stylus to “compress” the fabric together. This creates a “gathering” effect without puckers. If desired, a second row of stitching can be done for more ease.

**Edge stitch:** A row of top stitching very close to a seamed edge or folded edge, usually about 1/16th of an inch.

**Fabric- right side:** The side of the fabric which will be the exposed, outside part of a garment.

**Fabric- wrong side:** The inside of the fabric which will be the unexposed side or inside of a garment.

**French seam:** A seam sewn in two steps to encase the raw edges of the fabric within itself, giving a clean finish. 1- Wrong sides together, sew 1/4” seam. 2- Turn right sides together, stitch 3/8” seam. Total 5/8” seam allowance.

**Grainline- cross grain:** The direction of fabric going from selvage edge to selvage edge. In woven fabric, these would also be known as the weft threads of the weave.

**Grainline- on grain:** The direction of fabric running parallel to the selvage edge of the cloth. This is also referred to as the “lengthwise grain”. In woven fabric, these would also be known as the “warp” threads of the weave.

**Notch- outward:** Markings on the pattern that indicate an outward triangular cut outside the seam allowance. Notch markings will be arranged to show where two seam edges join properly together. A single wedge will often indicate a front piece, and 2 to 3 wedges together can indicate back pieces.

**Notch- snip:** Markings on the pattern that indicate a small “snip” into the seam allowance. Notch marking will be arranged to show where two seam edges join properly together. A single notch will often indicate a front piece, and 2 to 3 notches together can indicate back pieces.

**Overlock machine:** A specialized sewing

---

## Glossary (continued):

machine designed to sew and cut along the raw edge of a fabric seam with a networked stitch to secure the edges from fraying. Also known as a "serger" machine.

*Press cloth:* A piece of cloth used to lay over a garment to protect it while ironing from burning or scorching. Usually made of cotton or linen or wool.

*Raw edge:* The cut edge of fabric. If not secured with stitching or a finishing, the raw edge of a fabric can fray or unravel.

*Seam allowance:* The distance from the cut edge of a pattern piece to the sewing line. Seam allowances can vary, so be sure to double check the indicated amounts on your pattern.

*Stay stitch:* A row of stitching on a single layer of the seam allowance edge to prevent stretching. You are neither pushing or pulling the fabric- just guiding. The row of stitching will be just to the inside of the permanent seam allowance width. For example, if the seam allowance is 5/8", your stay stitch will be 1/2" or a "scant" 5/8". You will want your permanent stitching to conceal the stay stitch.

*Understitch:* A row of stitching on a the seamed edge of facing. This prevents the facing from rolling out to the outside and keeps it neatly in place along the garment edge. The stitching will only go on the facing side, catching the seam allowance with it. The stitching will show on the facing, but not on the garment side.



---

---

# *Thank you*

---

*We work hard on making our patterns beautiful enough to meet your standards.*

*If you feel like sharing praise or helpful criticism, please send us your comments to [ask@fabrics-store.com](mailto:ask@fabrics-store.com)*